

German steam locomotive V19-1001. Reversing and expansion gear arrangement.

A brief article by Allan Wallace © 2009, relating to a 5" g model built by Graeme Driscoll in South Australia.

This unusual locomotive was built in the late 1930s and was seen as a contender for the steam locomotive speed record. It featured four driven axles, each driven by a two cylinder double acting motor in a vee format. Each motor was mounted outboard of its wheelset and drove a wheel via a flexible torsion coupling. The steam valve for each cylinder was driven by an eccentric on the crankshaft.

Fixed eccentrics have been used since the beginning of the steam age to drive valves. In its simple form no adjustment is available and the engine cannot be reversed or "notched up". Notching up refers to a common feature in all more sophisticated valve gears that allows the operator to control the timing of the steam admission while the engine is running. This means that the engine can be optimised on the run for high torque (as when starting a heavy train) or high efficiency (when under way). The higher efficiency is obtained by allowing a smaller quantity of steam to expand further, thereby extracting more work per unit of steam. Smaller locomotives provided a pole lever in the driver's cab with a latch and a notched sector plate. At one extreme the lever sets the gear for full power in the forward direction, and at the other it is full power in reverse. As the lever is notched towards its mid position the steam admission timing is progressively reduced, often referred to as varying the "cutoff". As I said, a simple eccentric does not offer any of this control.

However, it is possible to provide a simple eccentric capable of reversing, using a "slip eccentric". It can rotate on the shaft between two positions corresponding to forward and reverse running. The positions are fixed by a stop collar, typically with a peg on the side of the eccentric resting against one of two lugs, depending on the direction of rotation.

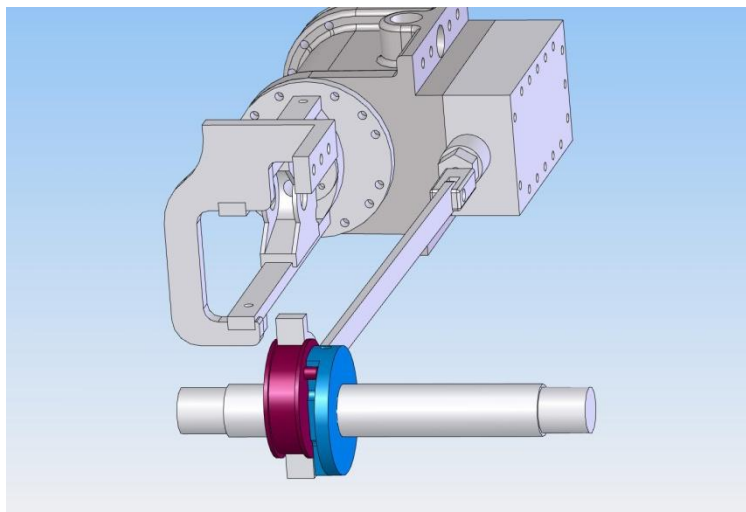

Figure 1 A typical slip eccentric (part of eccentric strap omitted)

However, the slip eccentric cannot be used to control the cutoff by taking up intermediate positions between forward and reverse. Without going into detail, the problem is that the middle of the eccentric describes an arc around the shaft axis as it slips between the forward and reverse stops.

What is needed is a mechanism to move the middle of the eccentric in a straight line between the full forward and full reverse positions.

Locomotive V19-1001 was fitted with a very clever mechanical arrangement which achieved this continuous straight-line motion in all the eccentrics of the four motors simultaneously. I have created a 3D model illustrating how it works as an animated video, and have extracted three images here for description.

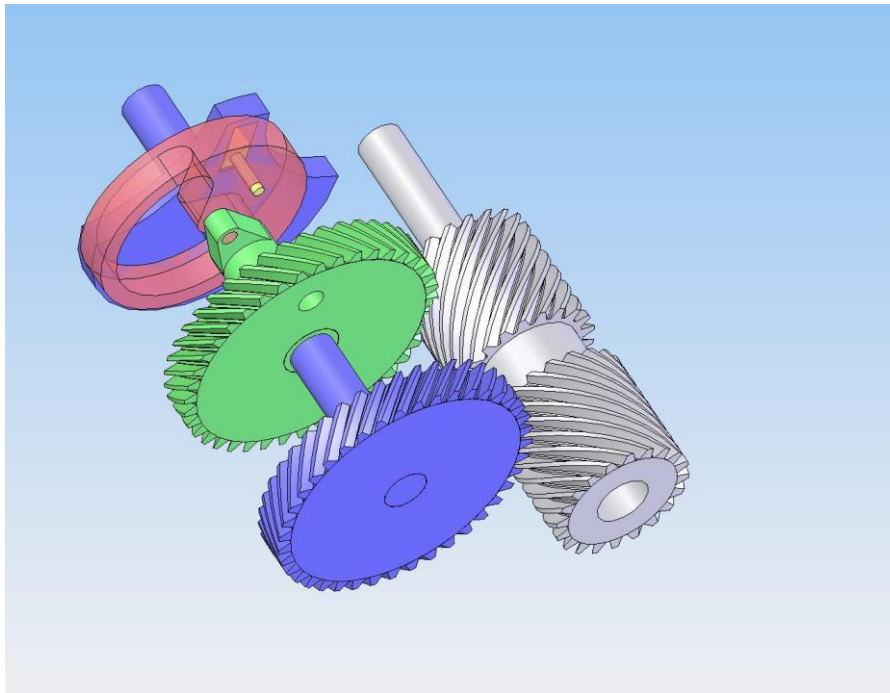

Figure 2 Full Forward gear

In the figure 2, the blue part is the crankshaft of the motor and the red part is the eccentric. The position of the eccentric relative to the shaft is controlled by the green component which I'll call a control arm. The control arm rotates with the shaft (except when the cutoff is being adjusted), effectively locking the eccentric relative to the shaft. Notice the small yellow slider and pin that holds the eccentric. The yellow slider, the green control arm, and the red eccentric provide the kinematics required for a straight line motion of the middle of the eccentric relative to the shaft. If one rotates the control arm relative to the shaft, the middle of the eccentric moves in a straight line between the full forward and full reverse positions. The control arm turns with the shaft by the mechanism of the gears. The blue gear on the shaft drives the grey idler gear on its counter shaft, and the other face of the idler gear drives the green control arm gear in a 1:1 ratio, since the blue and green gears have equal diameters.

Notice that the grey idler gear has two faces of helical gearing with opposite helix angle directions. This allows one to move the control arm relative to the shaft, and therefore move the eccentric on the run. As one moves the grey idler gear axially on its shaft (using a control fork which is not shown), the green gear moves relative to the blue gear. You can visualise this when the blue shaft is stopped, and the grey gear is translated away from you: the grey gear rotates anticlockwise. This

carries the green gear in a clockwise direction, and moves the eccentric towards the mid-gear position shown in figure 3. The same process occurs when the blue shaft is turning.

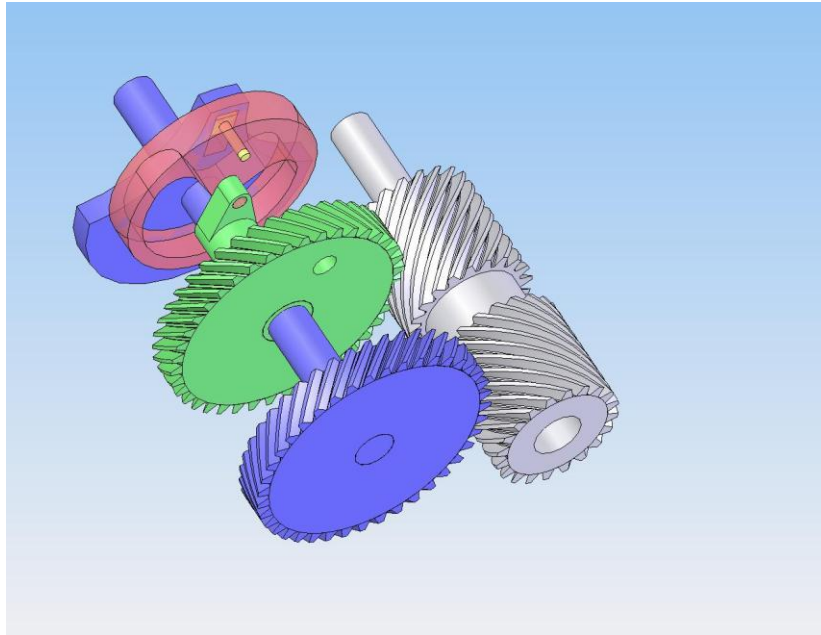

Figure 3 Mid gear

Notice in figure 3 that the grey gear is now centralised and the eccentric is in mid position. Further movement moves the eccentric towards the full reverse position shown in figure 4.

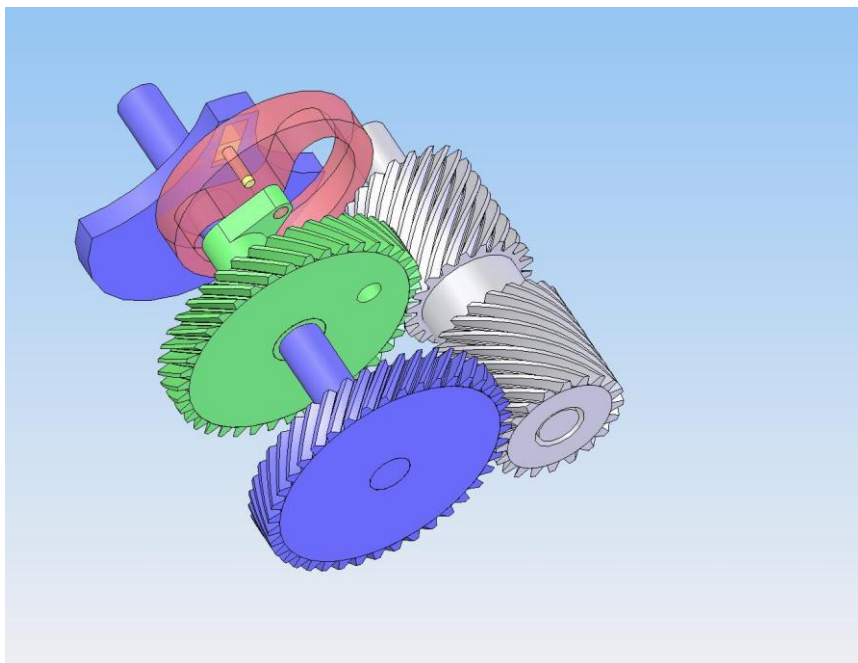

Figure 4 Full reverse gear

The rest of the story is straight forward. The control forks that move the grey idler gear axially were driven from a common shaft with bevel gears, universal joints and spline couplings running around

the locomotive, controlled from the driver's cab. In this way, the driver could wind a handle to move all the motors simultaneously between full forward gear and full reverse gear, with continuous expansion control.

I need to mention that Graeme did not fit the arrangement described above on his locomotive, because of its complexity. Instead, simple eccentrics as in figure 1 are used. One way to reverse is to give the engine a brief shove in the direction you want to go, then apply power. It's feasible in 5"g. However, the motors on Graeme's engine can be reversed from the cab using a push rod fitted with a gear rack inside each motor casing. The rack engages with a gear on the eccentric to move it to the alternative stop. The push rod mimics the action of the reversing shaft used on the prototype.

(7/12/2009)